

TENSION ACCESSORIES FOR MODEL 610
ZUGKRAFTZUBEHÖR FÜR MODELL 610

- Each accessory contains a set of the top and bottom.
- Das Zubehör beinhaltet ein oberen und ein unteren Satz von Teilen

Accessory Zubehör	Nominal load Nennlast	A	B	C	D	E [□]	F	Ultimate load Grenzlast	Transport weight Transportgewicht	Material
TE10x1.5	50-100 kg	194	58.9	76.2	M10x1.5	30	138	400 kg	0.7 kg	Steel zinc-plated
TE12x1.75	250...1000 kg	242.2	83	76.2	M12x1.75	35	154.2	2580 kg	1.4 kg	Verzinkter Stahl

Dimensions in mm. Abmessungen in mm.

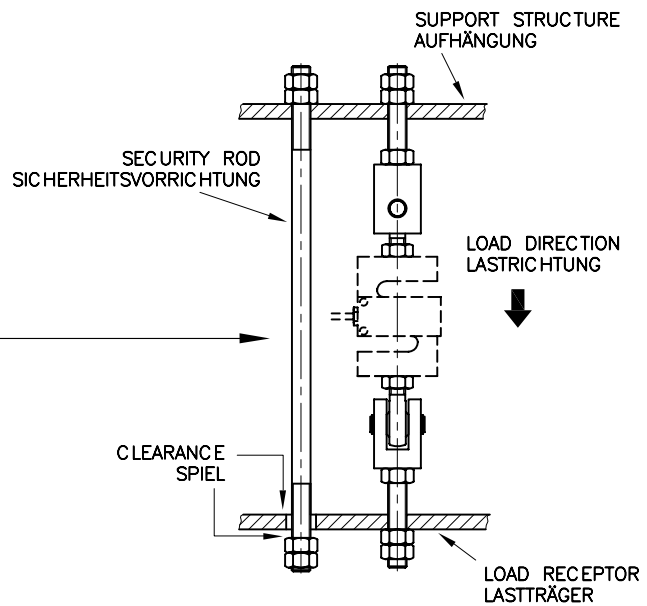
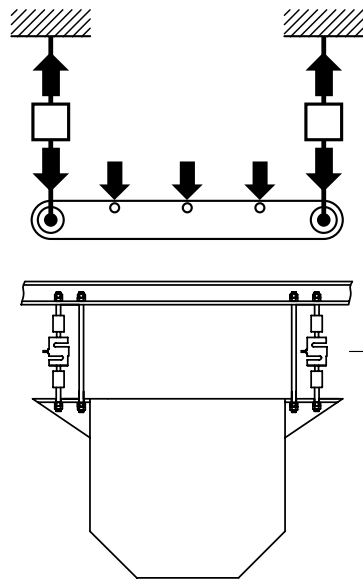
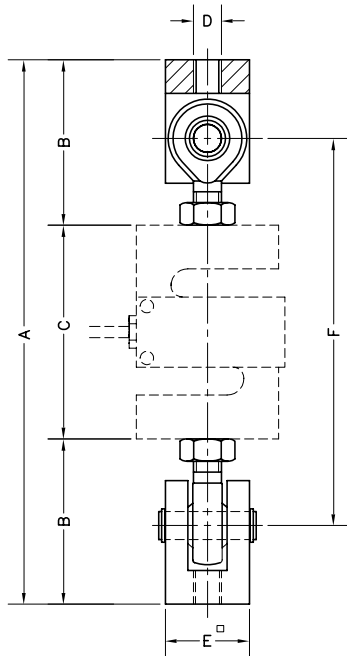
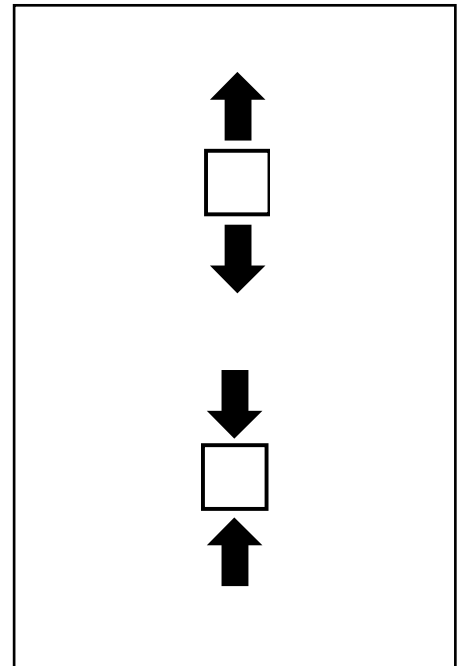

- Tension/compression load cell
- 3000 divisions OIML R60 class C
- Measuring element from Alloy Steel
- Protected IP 67 (EN 60529)
- Protected against corrosion by nickel-plated treatment
- Applications:
 - Suspended weighing in Tanks, Hoppers and Belt Conveyor Scales
 - Asphalt and Concrete Plants
 - Force measurement in Test Equipment
 - Crane scales

- Wägezelle für Druck/Zugkraft
- 3000 Teile OIML R60 Klasse C
- Messkörper aus Stahl
- Schutzart IP 67 (EN 60529)
- Korrosionsschutz durch Vernickelung
- Applikationen:
 - Schwebende Wägetrichtern und Wägebändern
 - Asphalt- und Betonanlagen
 - Kraftmessung bei Testmaschinen
 - Hängende Verwiegung

Model Modell	Nominal capacity Nennlast Ln	Accuracy class Genauigkeitsklasse n. OIML	Minimum division Kleinster Teilungswert vmin	Service load Gebrauchslast	Safe load Grenzlast
610 50 kg	50 kg	3000	5 g	75 kg	150 kg
610 100 kg	100 kg	3000	10 g	150 kg	300 kg
610 250 kg	250 kg	3000	25 g	375 kg	750 kg
610 500 kg	500 kg	3000	50 g	750 kg	1500 kg
610 1000 kg	1000 kg	3000	100 g	1200 kg	2000 kg

MODEL 610

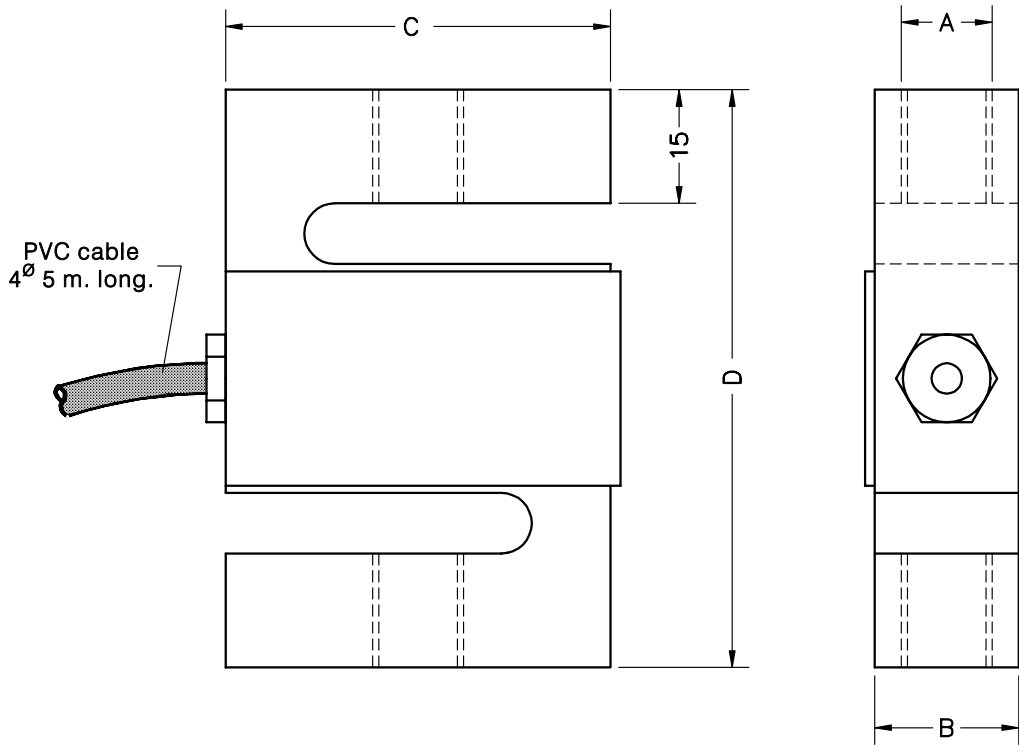

Nominal load Nennlast	A	B	C	D	Transport weight Transportgewicht
50-100 kg	M10x1.5	15	50.8	76.2	0.5 kg
250-500 kg	M12x1.75	19	50.8	76.2	0.6 kg
1000 kg	M12x1.75	25	49.5	75.0	0.7 kg

Dimensions in mm. Abmessungen in mm.

SPECIFICATIONS			TECHNISCHE DATEN
Nominal capacities (Ln)	50-100-250-500-1000	kg	Nennlasten (Ln)
Accuracy class	3000	n. OIML	Genauigkeitsklasse
Minimum dead load	0	%Ln	Minimale Vorlast
Service load	150	%Ln (1)	Gebrauchslast
Safe load limit	300	%Ln (2)	Grenzlast
Total error	< ±0.017	%Sn	Zusammengesetzter Fehler
Repeatability error	< ±0.015	%Sn	Wiederholgenauigkeit
Temperature effect: on zero	< ±0.01	%Sn/5 °C	Temperaturfehler: Nullpunkt
on sensitivity	< ±0.006	%Sn/5 °C	Kennwert
Creep error (30 minutes)	< ±0.016	%Sn	Kriechfehler (30 min)
Temperature compensation	-10...+40	°C	Nenntemperaturbereich
Temperature limits	-30...+70	°C	Arbeitstemperaturbereich
Nominal sensitivity (Sn)	3 ±0.25%	mV/V	Nennkennwert (Sn)
Nominal input voltage	10	V	Nom. Speisespannung
Maximum input voltage	15	V	Max. Speisespannung
Input impedance	400 ±20	Ω	Eingangswiderstand
Output impedance	350 ±3	Ω	Ausgangswiderstand
No load output	< ±2	%Sn	Nullsignaltoleranz
Insulation resistance	> 5000	MΩ	Isolationswiderstand
Maximum deflection (at Ln)	0.3-0.5	mm	Nennmessweg (bei Ln)

ELECTRICAL CONNECTION ELEKTRISCHER ANSCHLUSS:

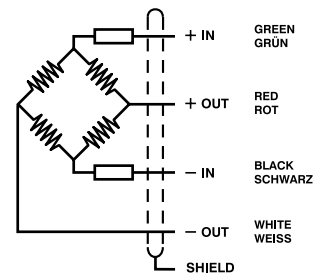

«OUTPUT SIGNS FOR TENSION APPLICATION»

«SIGNALPOLARITÄT FÜR ZUG-KRAFT»

(1) For 1000 kg: 120 % / Für 1000 kg: 120 %

(2) For 1000 kg: 200% / Für 1000 kg: 200%