

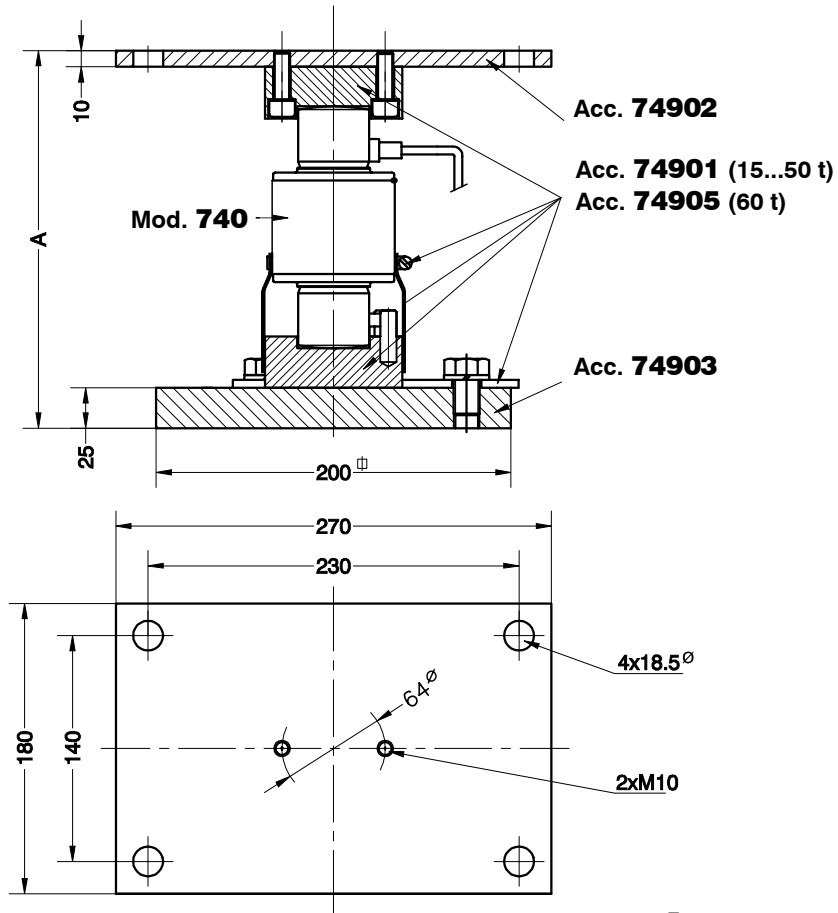

ACCESSORIES FOR MODEL 740 (15...60t)
ZUBEHÖR FÜR MODELL 740 (15...60t)

Accessory Zubehör	Model Modell	A	Accessory Zubehör	Transport Weight Transport- gewicht
74901 + 74902 + 74903	740 (15-20-25-30-40-50 t)	235	74901	3 kg
74905 + 74902 + 74903	740 (60 t)	295	74902	3.9 kg
			74903	9.7 kg
			74905	3 kg

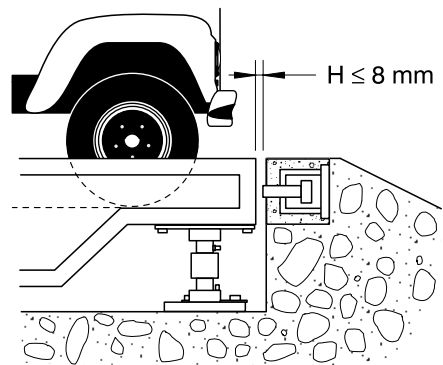
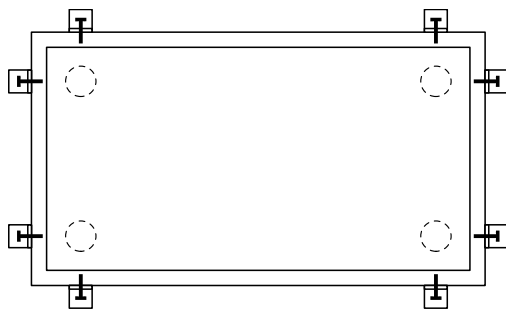
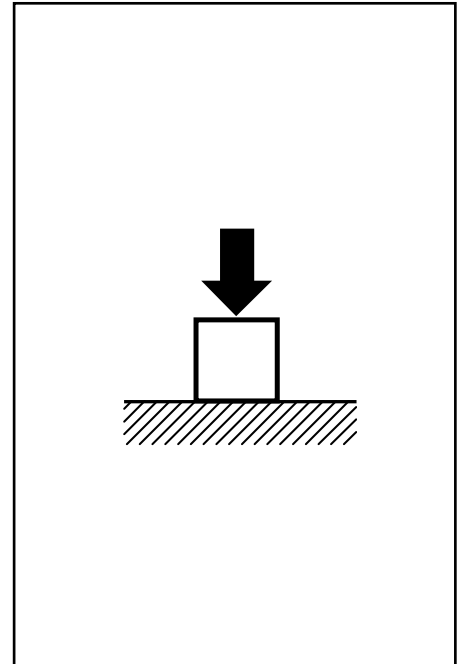

Dimensions in mm. Abmessungen in mm.



- Compression load cell, selfcentering column
- 4000 divisions OIML R60 class C
- Available in **ATEX**  version (optional) Zone 0-1-2 (gas) and 20-21-22 (dust)
- Simple to install
- Stainless Steel construction
- Hermetically welded, protection class IP 68 (EN 60529) and IP 69K (ISO 20653)
- Pre-corner adjustment optimized for multi-cell systems
- Lightning protection
- Applications: High capacity weighing systems, truck scales
- Schwerlastwägezelle, selbstzentrierend
- 4000 Teile OIML R60 Klasse C
- Erhältlich in **ATEX**  -Ausführung (optional) Zone 0-1-2 (Gas) und 20-21-22 (Staub)
- Einfache Montage
- Ausführung in Edelstahl
- Hermetisch dicht verschweißt Schutzart IP 68 (EN 60529) und IP 69K (ISO 20653)
- Abgeglichener Ausgang für problemlose Parallelschaltung
- Blitzschutz
- Applikationen: Schwerlastwaagen, Strassenfahrzeugwaagen

Model Modell	Nominal capacity Nennlast Ln	Accuracy class Genauigkeitsklasse n. OIML	Minimum division Kleinster Teilungswert vmin	Safe load limit Grenzlast 150 % Ln	Breaking load Bruchlast > 350 % Ln
740 15 t	15 t	4000	1.5 kg	22.5 t	> 52.5 t
740 20 t	20 t	4000	2 kg	30 t	> 70 t
740 25 t	25 t	4000	2.5 kg	37.5 t	> 87.5 t
740 30 t	30 t	4000	3 kg	45 t	> 105 t
740 40 t	40 t	4000	4 kg	60 t	> 140 t
740 50 t	50 t	4000	5 kg	75 t	> 175 t
740 60 t	60 t	4000	6 kg	90 t	> 210 t



MODEL 740 + ACC. 74901 (15...50 t)
ACC. 74905 (60 t)

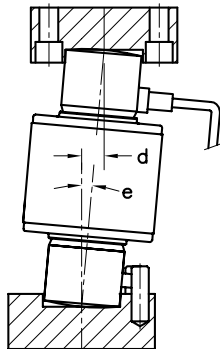
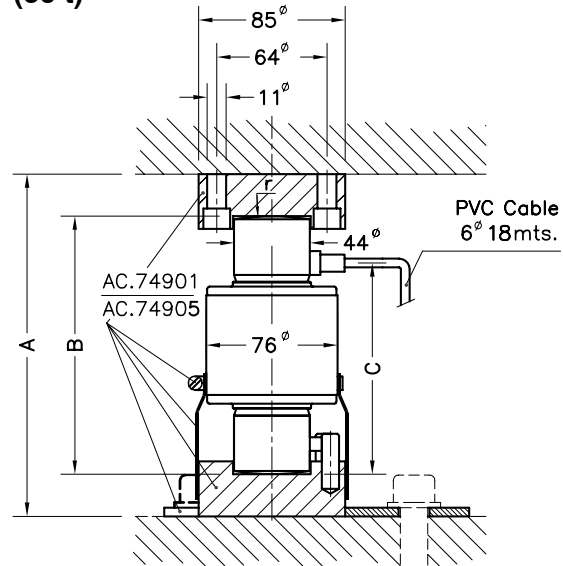
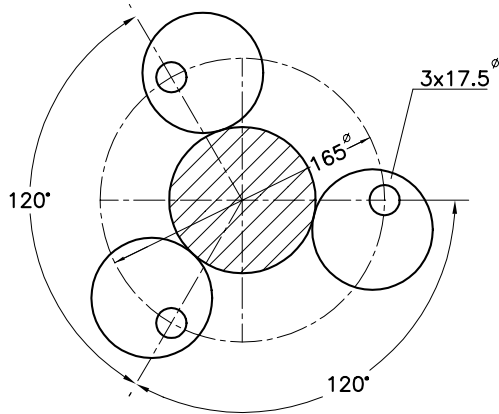

Load cells Wägezellen	A	B	C	d max.	e max. Max. Neigung	Radius Ball r	Transport Weight Transport- gewicht
740 15 t	200	150	123	13	5°	130	2.5 kg
740 20 t	200	150	123	13	5°	130	2.5 kg
740 25 t	200	150	123	13	5°	150	2.6 kg
740 30 t	200	150	123	13	5°	160	2.6 kg
740 40 t	200	150	123	13	5°	180	2.8 kg
740 50 t	200	150	123	13	5°	180	2.9 kg
740 60 t	260	210	153	11	3°	220	3.8 kg
Acc. 74901	---	---	---	---	---	---	3 kg
Acc. 74905	---	---	---	---	---	---	3 kg

Dimensions in mm. Abmessungen in mm.

SPECIFICATIONS			TECHNISCHE DATEN
Nominal capacities (Ln)	15-20-25-30-40-50-60	t	Nennlasten (Ln)
Accuracy class	4000	n. OIML	Genauigkeitsklasse
Minimum dead load	0	%Ln	Minimale Vorlast
Service load	120	%Ln	Gebrauchslast
Safe load limit	150	%Ln	Grenzlast
Total error	< ±0.013	%Sn	Zusammengesetzter Fehler
Repeatability error	< ±0.015	%Sn	Wiederholgenauigkeit
Temperature effect: on zero	< ±0.01	%Sn/5 °C	Temperaturfehler: Nullpunkt
on sensitivity	< ±0.006	%Sn/5 °C	Kennwert
Creep error (30 minutes)	< ±0.012	%Sn	Kriechfehler (30 min)
Temperature compensation	-10...+40	°C	Nenntemperaturbereich
Temperature limits	-50...+80	°C	Arbeitstemperaturbereich
Nominal sensitivity (Sn)	2	mV/V (1)	Nennkennwert (Sn)
Nominal input voltage	10	V	Nom. Speisespannung
Maximum input voltage	15	V	Max. Speisespannung
Input impedance	800 ±5	Ω	Eingangswiderstand
Output impedance	705 ±5	Ω	Ausgangswiderstand
No load output	±2	%Sn	Nullsignaltoleranz
Insulation resistance	> 5000	MΩ	Isolationswiderstand
Maximum deflection (at Ln)	0.6-1	mm	Nennmessweg (bei Ln)

(1) Pre-corner adjustment optimized at ±0.05% by output current calibration /
Auf ±0.05% optimierter Eckenvorabgleich durch Stromkalibrierung des Ausgangssignals

**ELECTRICAL CONNECTION
ELEKTRISCHER ANSCHLUSS:**

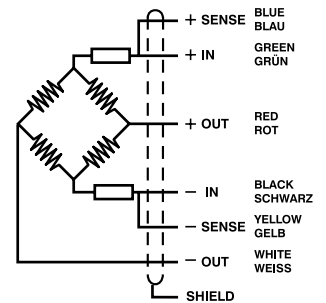

«SENSES»: 2 additional wires to maintain a constant voltage supply at the load cell when used with proper instrumentation. Use specially when long wires and wide temperature range.
SHIELD: Not connected to transducer body.

"SENSE-Leitung": zwei zusätzliche Adern, um eine konstante Spannungsversorgung an der Wägezelle zu gewährleisten, wenn entsprechende Elektronik verwendet wird. Speziell bei langen Leitungen und grossem Temperaturunterschied auf der Leitung.
SCHIRM: nicht am Wägezellenkörper angeschlossen.

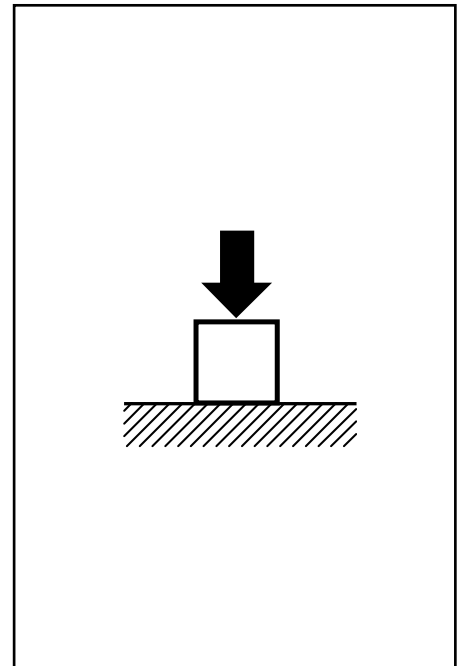

- Digital compression load cell, selfcentering column
 - 4000 divisions OIML R60 class C
 - Stainless Steel construction
 - Hermetically welded, protection class IP 68 (EN 60529) and IP 69K (ISO 20653)
 - Lightning protection
 - Digital interface RS-485 fullduplex
 - Configuration and updatable software through serial interface
 - Advantages in system setup, corner adjustment and individualized diagnosis
 - Applications: High capacity weighing systems, truck scales
- Digitale Schwerlastwägezelle, selbstzentrierend
 - 4000 Teile OIML R60 Klasse C
 - Ausführung in Edelstahl
 - Hermetisch dicht verschweißt Schutzart IP 68 (EN 60529) und IP 69K (ISO 20653)
 - Blitzschutz
 - Digitales Interface RS-485 Fullduplex
 - Systemeinstellungen und SW-Update über serielle Schnittstelle
 - Vorteile bei der Inbetriebnahme, beim Eckenabgleich und durch individuelle Diagnose
 - Applikationen: Schwerlastwaagen, Strassenfahrzeugwaagen

Model Modell	Nominal capacity Nennlast Ln	Accuracy class Genauigkeitsklasse n. OIML	Minimum division Kleinster Teilungswert vmin	Safe load limit Grenzlast 150 % Ln	Breaking load Bruchlast > 350 % Ln
740D 15 t	15 t	4000	1.25 kg	22.5 t	> 52.5 t
740D 30 t	30 t	4000	2.5 kg	45 t	> 105 t
740D 40 t	40 t	4000	3.33 kg	60 t	> 140 t
740D 50 t	50 t	4000	4.17 kg	75 t	> 175 t
740D 60 t	60 t	4000	5 kg	90 t	> 210 t



MODEL 740D + ACC. 74901 (15...50 t)
ACC. 74905 (60 t)

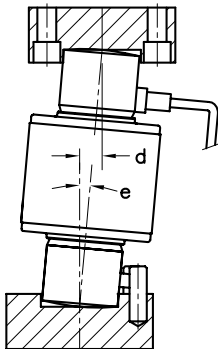
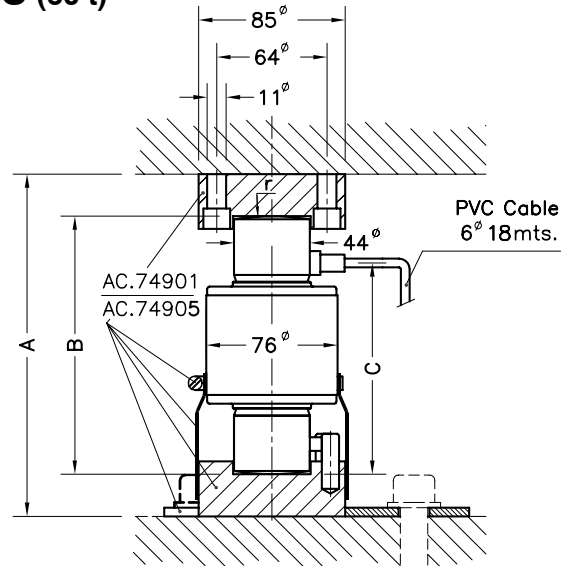
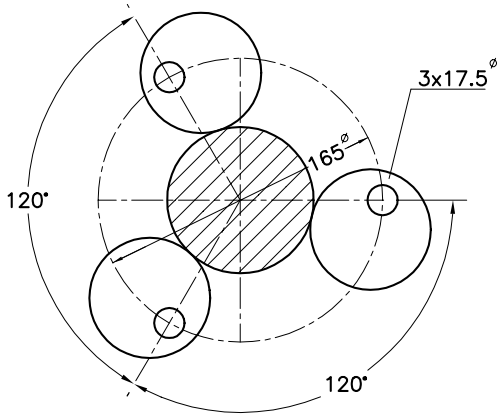

Load cells Wägezellen	A	B	C	d	e max. Max. Neigung	Radius Ball r	Transport Weight Transport- gewicht
740D 15 t	200	150	123	13	5°	130	2.5 kg
740D 30 t	200	150	123	13	5°	160	2.6 kg
740D 40 t	200	150	123	13	5°	180	2.8 kg
740D 50 t	200	150	123	13	5°	180	2.9 kg
740D 60 t	260	210	153	11	3°	220	3.8 kg
Acc.74901	-	-	-	-	-	-	3 kg
Acc.74905	-	-	-	-	-	-	3 kg

Dimensions in mm. Abmessungen in mm.

SPECIFICATIONS			TECHNISCHE DATEN
Nominal capacities (Ln)	15-30-40-50-60	t	Nennlasten (Ln)
Accuracy class	4000	n. OIML	Genauigkeitsklasse
Minimum dead load	0	%Ln	Minimale Vorlast
Service load	120	%Ln	Gebrauchslast
Safe load limit	150	%Ln	Grenzlast
Total error	< ±0.013	%Sn	Zusammengesetzter Fehler
Repeatability error	< ±0.01	%Sn	Wiederholgenauigkeit
Temperature effect: on zero	< ±0.01	%Sn/5 °C	Temperaturfehler: Nullpunkt
on sensitivity	< ±0.006	%Sn/5 °C	Kennwert
Creep error (30 minutes)	< ±0.012	%Sn	Kriechfehler (30 min)
Temperature compensation	-10...+40	°C	Nenntemperaturbereich
Temperature limits	-30...+70	°C	Arbeitstemperaturbereich
Nominal sensitivity (Sn)	200000±0.05%	counts (1)	Nennkennwert (Cn)
No load output	±0.1	%Sn	Nullsignaltoleranz
Power supply	8...18	V DC	Stromversorgung
Supply current	60	mA (max.)	Stromaufnahme
RS-485 Serial interface	Full duplex		RS-485 Serial interface
Max. transmission cable length	1200	m	Max. Kabellänge
Maximum deflection (at Ln)	0.6-1	mm	Nennmessweg (bei Ln)

ELECTRICAL CONNECTION
ELEKTRISCHER ANSCHLUSS:

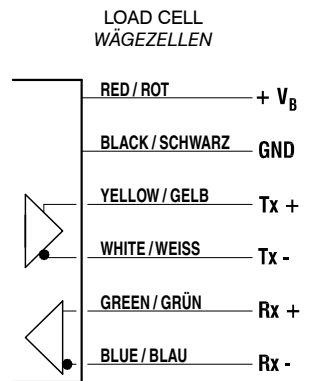

(1) User programmable / Benutzerprogrammierbar

ACCESSORIES AND SCHEMATIC CONNECTION DIGITAL LOADCELL
ZUBEHÖR UND SCHEMATISCHE VERBINDUNG DIGITALE WÄGEZELLE

