

## Bluetooth Strain Transmitter

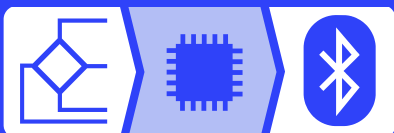

### Product Features

- Wide Input Sensitivity:**  
 B24-SSB has four sensitivity range settings ( $\pm 6$  mV/V,  $\pm 12$  mV/V,  $\pm 24$  mV/V &  $\pm 48$  mV/V) which allows it to accurately produce measurements from a wide range of sensors.
- High Measurement Resolution:**  
 B24-SSB can produce a noise free resolution of 1 in 92000 counts (16.5 bit) when used with a 3mV/V sensor and 1 in 184,000 counts (17.5 bit) when used with a 6mV/V sensor.
- Simple Integration Into iOS and Android Apps:**  
 Advert format & encoding as well as details on connected services are available to facilitate integration of the device within custom apps for OEM applications.
- Range:**  
 Ranges achievable between 30 to 90 m line of sight depending on age and quality of viewing device.
- Advanced Protection:**  
 Configuration PIN, View PIN & Calibration PIN allow you to take control of your end users' experience and prevent any unwanted changes in configuration that can compromise measurement quality.



### Introduction

The B24-SSB is a Bluetooth Low Energy (BLE) strain bridge transmitter module that provides access to high quality measurements on a mobile platform such as a phone or tablet.

The delivery mechanism is BLE which utilises the flexibility and availability of Bluetooth receivers while maintaining the low power requirements of embedded systems.

B24 is built upon two complimentary principles of BLE, broadcast advertising data which enables users to deliver the same data to multiple receivers simultaneously and low power paired connections which can be used in a point to point system.

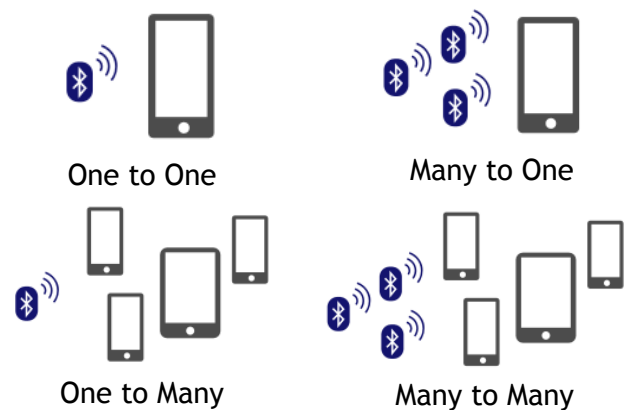

B24-SSB comes in two versions:

- Housed in an our 'C' style enclosure with integrated battery holder, which makes it suitable for integration
- Bare board format, which allows the module to be built into OEM applications

### Mobile Application



A free iOS and Android app is available to download, which enables users to create dashboards with varying degree of detail based on application requirement. It enables B24 systems to be visualised on phones and tablets by using digital displays, gauges, tanks and charts. Displayed data can be defined as mathematical expressions consisting of readings from multiple transmitters, functions and constants. The app also facilitates B24 module configuration and calibration.

## Specifications

Parameter	
Strain Gauge Excitation System	4 Wire
Strain Gauge Excitation Voltage (Nom)	3 V dc
Strain Gauge Drive Capability	85 to 5000 ohms
Strain Gauge Sensitivity	Up to $\pm 48$ mV/V
Offset Temperature Stability	$\pm 5$ ppm / $^{\circ}\text{C}$
Gain Temperature Stability (Max)	4 ppm / $^{\circ}\text{C}$
Non Linearity before Linearization	6 ppm of FR
Internal Resolution	24 bits
<b>Noise free resolution @ 2.5 mV/V:</b>	
At 1 sample	14.25 bits
At 2 samples	15.25 bits
At 4 samples	16.00 bits
At 8 samples	16.75 bits

## Battery Life at 1 Sample per Second

2 X AA cells, Transmitting 24 hr/day	10 months
--------------------------------------	-----------

## Power Supply

Standby (Max)	10 $\mu\text{A}$
Power Supply Voltage	2.3 – 3.6 Vdc
Power Supply Ripple	50 mV ac pk-pk
Peak Current (1K Bridge)	30 mA

## Environmental

Operating Temperature Range	-40 to +85 $^{\circ}\text{C}$
Storage Temperature Range	-40 to +85 $^{\circ}\text{C}$
Maximum Humidity	Up to 95% non condensing
Protection (B24-SSBC only)	IP67

## Dimensions

'C' Style Enclosure	80 x 62 x 34 mm
---------------------	-----------------

## Mechanical

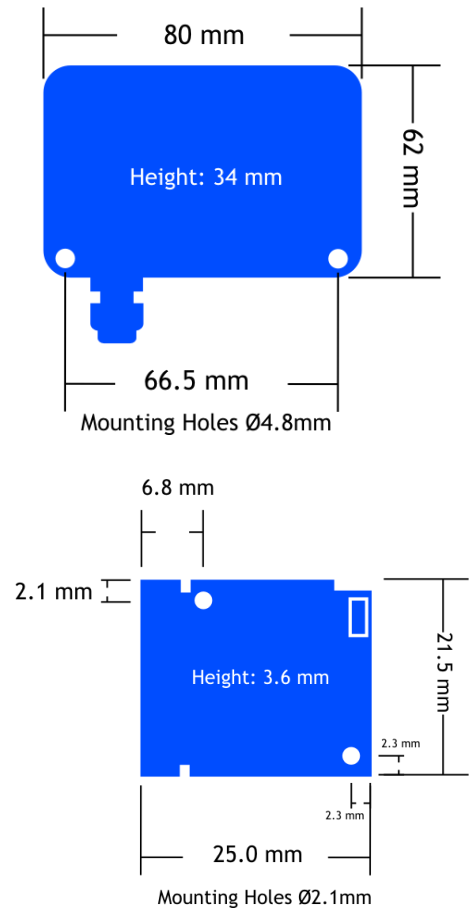

## Electrical

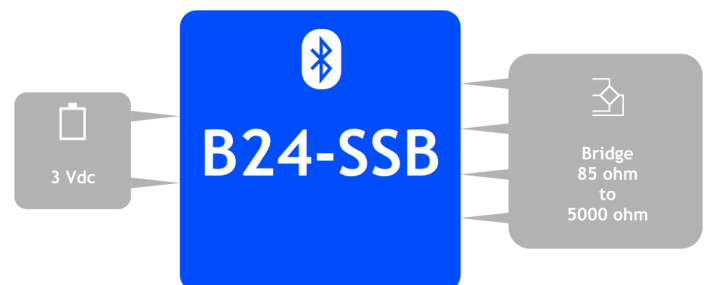

## Order Codes

### B24-SSBC

Bluetooth Telemetry Strain Bridge Sensor TX in a 'C' style enclosure

### B24-SSBX

Bluetooth Telemetry Strain Bridge Sensor TX OEM Board

### Distributor:

UTILCELL s.r.o.  
nám. V. Mrštíka 40,  
664 81 Ostrovačice  
Czech Republic

### Manufacturing factory:

Mantracourt Electronics Ltd  
The Drive, Farringdon, Exeter,  
Devon, EX5 2JB, UK

