



FSU-SSB

UTILCELL

LOAD CELLS - SNÍMAČE SIL

+ Value in Weigh Tech
Hodnota ve vážící technice

Fast USB Strain Module



Introduction

The FSU-SSB is a fast, compact, high precision strain bridge input module delivering high resolution readings over USB and communicated directly to a PC. It is aimed at dynamic applications that require high speed measurement.

It delivers high speed measurements of 4800 samples per second at 13 bits noise free resolution.

Simply by plugging the device into a PC, data can be measured from a sensor using the FSU-SSB for a wide range of high speed systems. This is achieved using the powerful Toolkit software, which has been developed in-house by our design engineers to provide optimised, fast viewing of data.

It allows the viewing of input status and module information, simple switching between engineering units as well as two part calibration, high speed navigation and FFT frequency component analysis. Data can be exported to a CSV file.

This free-standing module is fitted with 9-way 'D' type socket for connection to the strain bridge or load cell while a micro USB socket allows connection to a PC and does not require external power. A DIN rail mounting option is also available.

Product Features & Benefits

- **Quick Setup:**
Simple USB 'Plug and Measure' device connects to a PC directly, allowing quick setup
- **High Speed Measurement:**
4800 samples per second at 13 bits noise free resolution. Ideal for impact, drop, non-rotational torque, vibration and materials testing
- **Powerful & Intelligent Toolkit Software:**
Easy connection to free FSU Toolkit software for fast, optimised measurement and frequency analysis
- **Quick, Real-time Data Analysis:**
Capture up to 30 minutes of data in real-time (8.64 million data points)
- **Advanced Security:**
OEM level configuration and calibration can be saved, locked and restored for security of setup

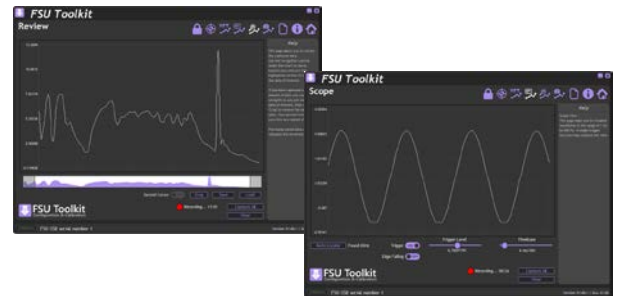

Accessories



FSU-SSB-A
OEM version of FSU-SSB



FSU Toolkit
Toolkit software



D4
Din Rail Mounting Kit

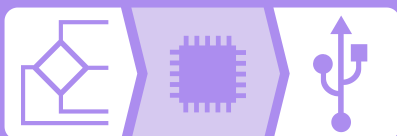

Specifications

Parameter

Strain Gauge Measurement	4 Wire
Strain Gauge Excitation Voltage	5 V dc
Strain Gauge Drive Capability	85 to 5000 ohms
Strain Gauge Sensitivity	3 mV/V
Offset Temperature Stability	4 ppm / °C
Gain Temperature Stability	5 ppm / °C
Offset Stability with Time	90 ppm of FR (1)
Gain Stability with Time	30 ppm of FR (2)
Non Linearity before Linearization	25 ppm of FR
Internal Resolution	16 Million Counts/divs
Resolution @ 4.8kHz readings (Noise stable) over 1s	8192 Counts/divs
Resolution @ 4.8kHz readings (Noise stable) over 1s	13 Bits
Measurement Sample Rate (Contains no anti-aliasing analogue filter)	4800 Per Second
Measurement Sample Rate Accuracy	±1.1 %

Electrical

Power Supply Voltage (USB)	5 V dc
Power Supply Current (350 Ohm Bridge)	68 mA

Data Transmission

Maximum Output Cable Length	5 m
------------------------------------	-----

Environmental

Operating temperature range	-40 to +85 °C
Storage temperature range	-40 to +85 °C
Maximum Humidity	95% RH
Protection	IP50

Dimensions

Cased Version	70.5 x 51 x 20mm excluding 9-way 'D' type socket connector.
	74.5 x 51 x 20mm including connector.

Mechanical

FSU-SSBD-A

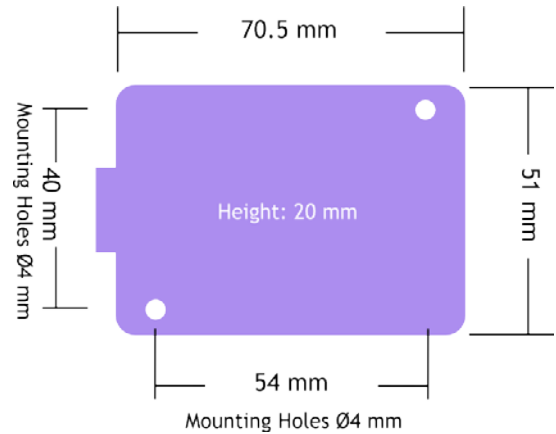

FSU-SSBX-A

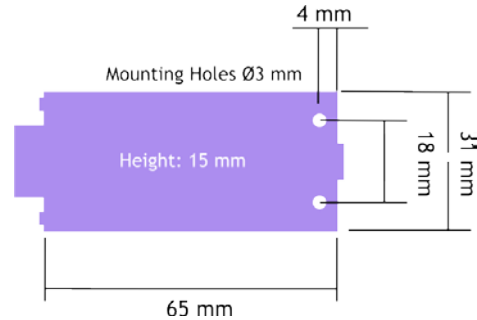

Electrical



Order Codes

FSU-SSBD-A

Fast USB Strain Module

FSU-SSBD-B

Fast USB Strain Module Unbranded

FSU-SSBX-A

Fast USB Strain Module OEM

D4

Din Rail Mounting Kit

Distributor:

UTILCELL s.r.o.
nám. V. Mrštíka 40,
664 81 Ostrovačice
Czech Republic

Manufacturing factory:

Mantracourt Electronics Ltd
The Drive, Farrington, Exeter,
Devon, EX5 2JB, UK





FSU-SSB



UTILCELL

LOAD CELLS - SNÍMAČE SIL



Value in Weigh Tech
Hodnota ve vážicí technice

FSU TOOLKIT SOFTWARE

EASY TO USE, INTUITIVE TOOLKIT SOFTWARE FOR SPEEDY AND PAINLESS SET-UP

- **CONNECT IN SECONDS** - with PC auto detection there's no scrolling through lists of product codes.
- **INTUITIVE INTERFACE** - you don't have to read a manual to get started. Our well-designed interface gives you highlighted options so you know what's click-able.
- **LOGICAL** - our Toolkits configure, calibrate and provide logging functionality.
- **WE DO THE THINKING FOR YOU** - our toolkits have useful help panels at each stage of the process to help you make the right choice
- **USE ONE, USE THEM ALL** - our icon based navigation is common to all Toolkits. If you're familiar with one Toolkit you'll quickly pick up the others.
- **FREE** - all of our software is freely available.

TAKE A TOUR



WHAT CAN IT DO?

The FSU Toolkit software for Windows connects with the FSU modules via a micro USB to USB lead. The Toolkit allows configuration, calibration, modules management and data recording and review.

- Viewing of input with indication of integrity errors
- Two point auto calibration
- Engineering units selection and conversion
- Save, review and restore settings to a file
- Capture up to 30 mins of data at 4800 Hz and save to CSV file
- Trend chart of real-time data
- FFT frequency analysis
- Simple Oscilloscope view

THE DASHBOARD

- Icon based intuitive navigation
- Help panels in 'plain English'
- Interactive elements highlighted purple

DOWNLOAD & TEST-DRIVE

Visit mantracourt.com



FUNCTIONALITY SCREEN SHOTS

CALIBRATION

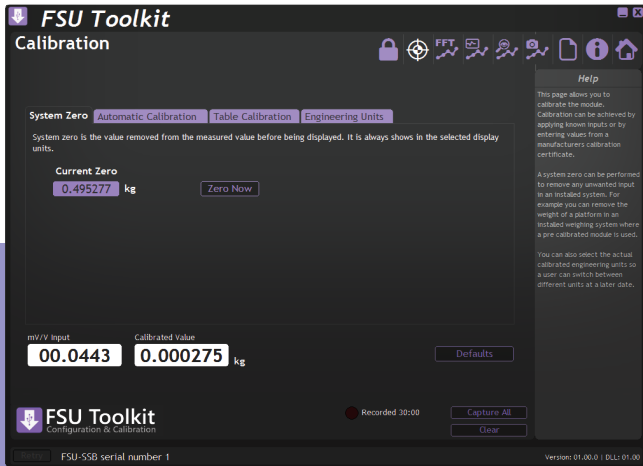

Two-point or automatic calibration in your chosen engineering units can be achieved by applying known inputs or entering values from a sensor calibration certificate. System zero is available to remove permanent values from an installed system to give a zero gross value. It allows you to specify the actual engineering units that the module was calibrated in for ease of use.

REVIEW

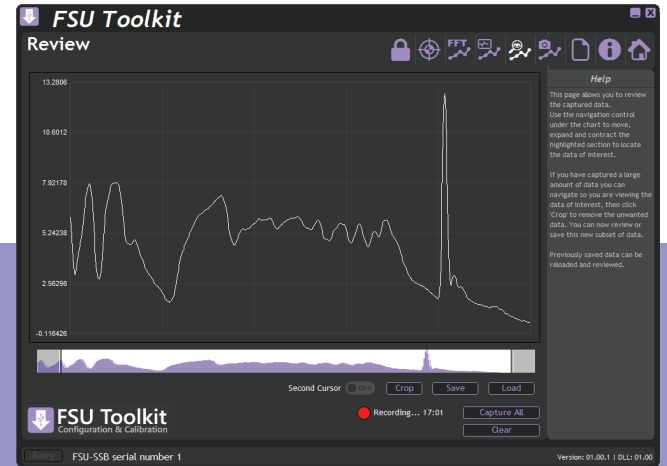

This window allows you to review up to 30 minutes of captured data, navigate and highlight data of interest (using the navigation bar beneath the graph) and discard any unwanted data. The chart automatically enhances transient peaks so that there is no chance of missing important features. This data can also be extracted, saved and previously saved data can also be loaded and reviewed.

SCOPE

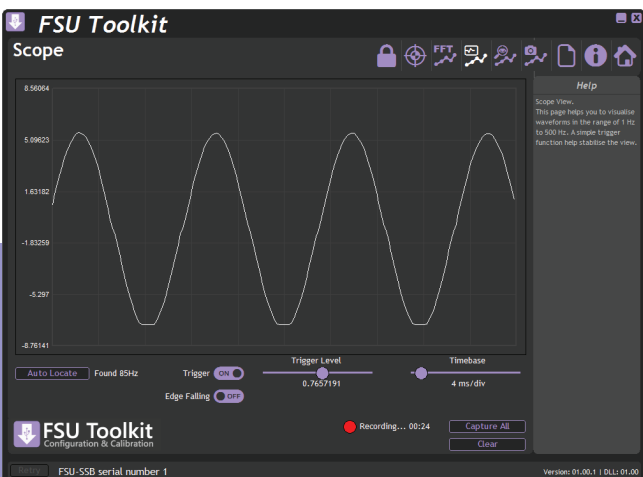

This page offers a simple oscilloscope to view the wave form input signal to help visualise what is happening and to detect patterns in data. From this page you have the ability to Clear the current recording or click Capture All to capture the entire recording and display it in the Review page.

This page best allows viewing of frequencies of between 1 Hz and 500 Hz.

FFT

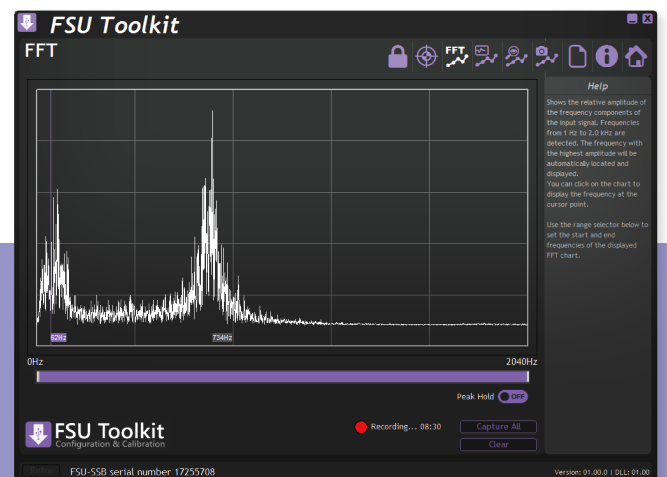

This function shows the relative amplitude of the frequency components of the input signal at a glance. Frequencies from 1 to 2 kHz are detected. The frequency with the highest amplitude will be automatically located and displayed providing quick troubleshooting.

The navigation options allow you to zoom into the frequency range that is of interest.