

- Tension/compression load cell
- 3000 divisions OIML R60 class C
- Measuring element from Alloy Steel
- Protected IP 67 (EN 60529)
- Protected against corrosion by nickel-plated treatment
- Applications:
 - Suspended weighing in Tanks, Hoppers and Belt Conveyor Scales
 - Asphalt and Concrete Plants
 - Force measurement in Test Equipment
 - Crane scales

- Wägezelle für Druck/Zugkraft
- 3000 Teile OIML R60 Klasse C
- Messkörper aus Stahl
- Schutzart IP 67 (EN 60529)
- Korrosionsschutz durch Vernickelung
- Applikationen:
 - Schwebende Wägetrichtern und Wägebändern
 - Asphalt- und Betonanlagen
 - Kraftmessung bei Testmaschinen
 - Hängende Verwiegung

Model Modell	Nominal capacity Nennlast Ln	Accuracy class Genauigkeitsklasse n. OIML	Minimum division Kleinster Teilungswert vmin	Service load Gebrauchslast	Safe load Grenzlast
610 50 kg	50 kg	3000	5 g	75 kg	150 kg
610 100 kg	100 kg	3000	10 g	150 kg	300 kg
610 250 kg	250 kg	3000	25 g	375 kg	750 kg
610 500 kg	500 kg	3000	50 g	750 kg	1500 kg
610 1000 kg	1000 kg	3000	100 g	1200 kg	2000 kg

MODEL 610

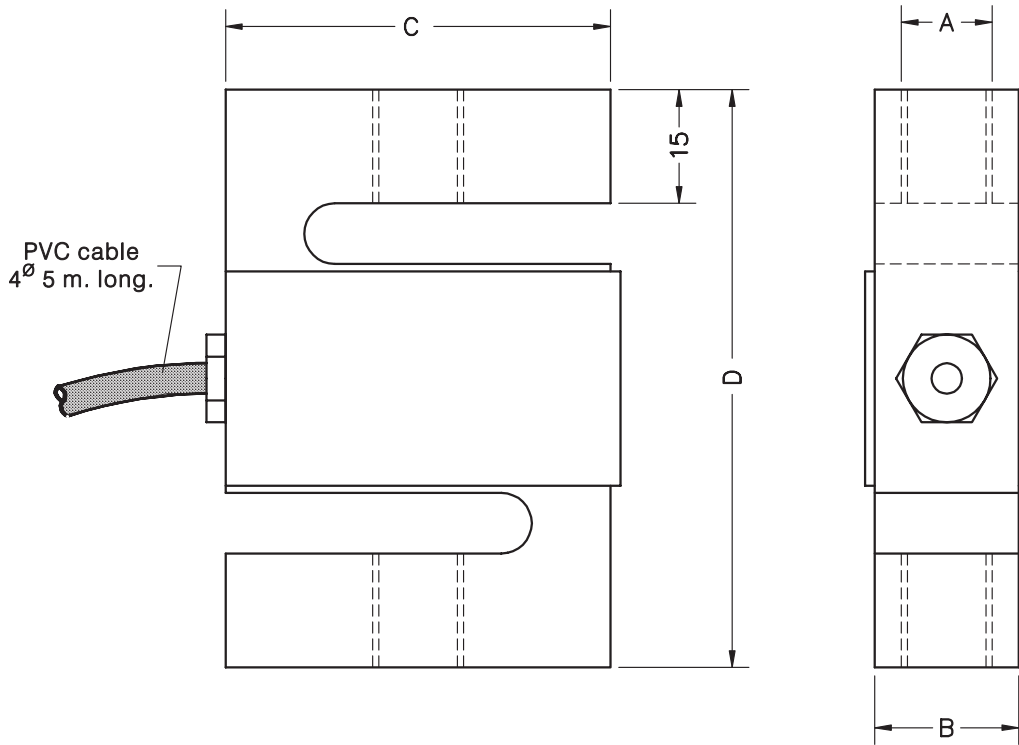

Nominal load Nennlast	A	B	C	D	Transport weight Transportgewicht
50-100 kg	M10x1.5	15	50.8	76.2	0.5 kg
250-500 kg	M12x1.75	19	50.8	76.2	0.6 kg
1000 kg	M12x1.75	25	49.5	75.0	0.7 kg

Dimensions in mm. Abmessungen in mm.

SPECIFICATIONS			TECHNISCHE DATEN
Nominal capacities (Ln)	50-100-250-500-1000	kg	Nennlasten (Ln)
Accuracy class	3000	n. OIML	Genauigkeitsklasse
Minimum dead load	0	%Ln	Minimale Vorlast
Service load	150	%Ln (1)	Gebrauchslast
Safe load limit	300	%Ln (2)	Grenzlast
Total error	< ± 0.017	%Sn	Zusammengesetzter Fehler
Repeatability error	< ± 0.015	%Sn	Wiederholgenauigkeit
Temperature effect: on zero	< ± 0.01	%Sn/5 °C	Temperaturfehler: Nullpunkt
on sensitivity	< ± 0.006	%Sn/5 °C	Kennwert
Creep error (30 minutes)	< ± 0.016	%Sn	Kriechfehler (30 min)
Temperature compensation	-10...+40	°C	Nenntemperaturbereich
Temperature limits	-30...+70	°C	Arbeitstemperaturbereich
Nominal sensitivity (Sn)	3 $\pm 0.25\%$	mV/V	Nennkennwert (Sn)
Nominal input voltage	10	V	Nom. Speisespannung
Maximum input voltage	15	V	Max. Speisespannung
Input impedance	400 ± 20	Ω	Eingangswiderstand
Output impedance	350 ± 3	Ω	Ausgangswiderstand
No load output	< ± 2	%Sn	Nullsignaltoleranz
Insulation resistance	> 5000	M Ω	Isolationswiderstand
Maximum deflection (at Ln)	0.3-0.5	mm	Nennmessweg (bei Ln)

ELECTRICAL CONNECTION
ELEKTRISCHER ANSCHLUSS:

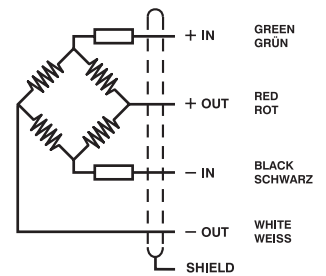

«OUTPUT SIGNS FOR TENSION APPLICATION»

«SIGNALPOLARITÄT FÜR ZUG-KRAFT»

(1) For 1000 kg: 120 % / Für 1000 kg: 120 %

(2) For 1000 kg: 200% / Für 1000 kg: 200%

TENSION ACCESSORIES FOR MODEL 610
ZUGKRAFTZUBEHÖR FÜR MODELL 610

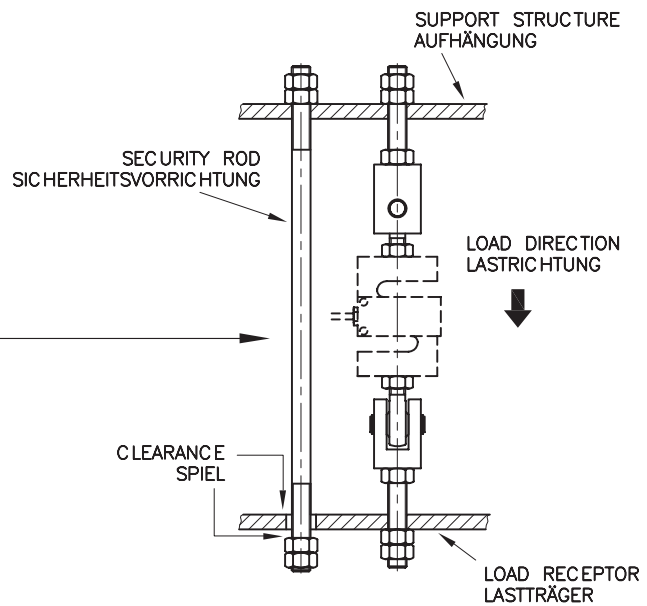
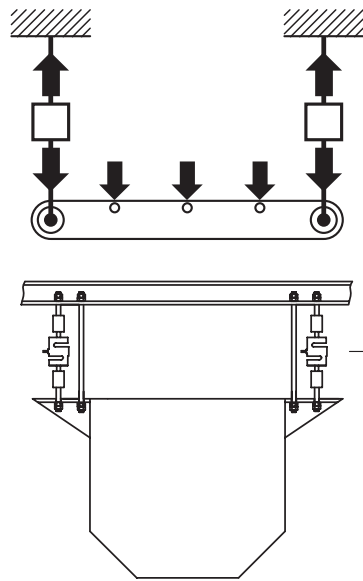
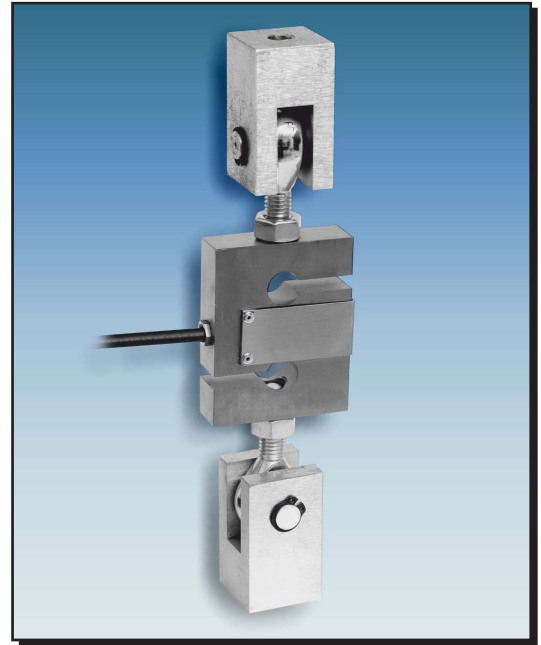
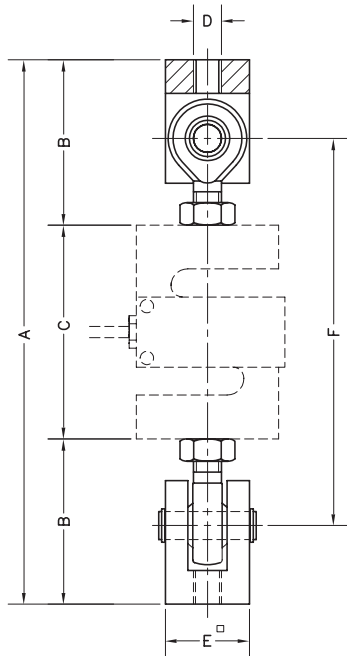

- Each accessory contains a set of the top and bottom.
- Das Zubehör beinhaltet ein oberen und ein unteren Satz von Teilen

Accessory Zubehör	Nominal load Nennlast	A	B	C	D	E [□]	F	Ultimate load Grenzlast	Transport weight Transportgewicht	Material
TE10x1.5	50-100 kg	194	58.9	76.2	M10x1.5	30	138	400 kg	0.7 kg	Steel zinc-plated
TE12x1.75	250...1000 kg	242.2	83	76.2	M12x1.75	35	154.2	2580 kg	1.4 kg	Verzinkter Stahl

Dimensions in mm. Abmessungen in mm.

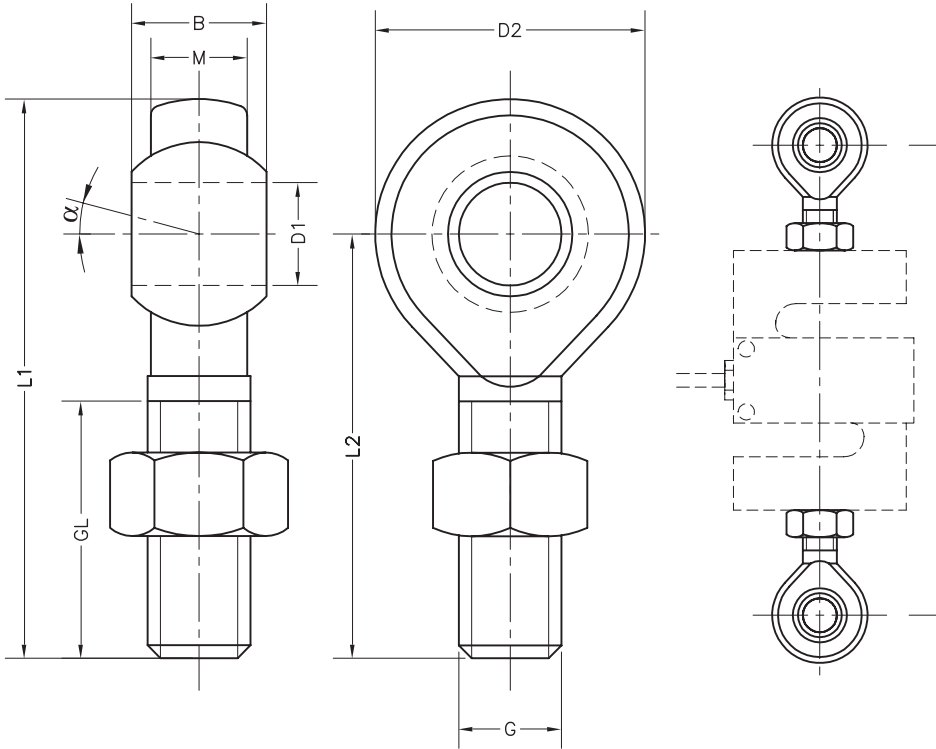
ROD ENDS FOR MODEL 610
GELENKKÖPFE FÜR MODELL 610

- **Material: Steel zinc-plated**
- **Each accessory RO includes a set of: 2 rod ends and 2 nuts**

- **Material: Verzinkter Stahl**
- **Jedes Zugkraftzubehör beinhaltet ein Satz von: 2 Gelenkköpfe und 2 Muttern**

RO Accessories Dimensions / RO Abmessungen Zubehör												
Accessory Zubehör	Capacity/ Nennlast (kg)	D2	B	M	D1	L1	L2	GL	G	α	F	Trans. weight Transportgewicht
RO10x1.5	50-100	28	14	10.5	Ø10	62	48	29	M10x1.5	13°	138	0.2 kg
RO12x1.75	250-500-1000	32	16	12.0	Ø12	70	54	33	M12x1.75	13°	154.2	0.2 kg

Dimensions in mm. Abmessungen in mm.